

# DOUBLE K™ CHALLENGAIR™ INDUSTRIES

## 2000XL™



### INSTRUCTION MANUAL

**PLEASE READ ALL INSTRUCTIONS AND SAFETY  
PRECAUTIONS BEFORE OPERATING PRODUCT!  
SAVE FOR FUTURE REFERENCE, WARRANTY PERTINENT  
CONTENT.**

#### **Product Specifications:**

##### **Model: 2000XL**

Voltage: 115v	Voltage: 230v
Amperage: 9.11	Amperage: 4.56
Horse Power: 3	Horse Power: 3
Wattage: 1048	Wattage: 1048
Hertz: 60	Hertz: 50/60
Motor Air Volume: 124 CFM	Motor Air Volume: 124 CFM

9711 Mason Avenue Chatsworth, CA 91311  
(818) 772-2887 (800) 821-9449 Fax: (818) 886-0218  
www.DoubleKIndustries.com info@DoubleKIndustries.com

#### IMPORTANT SAFEGUARDS

**WARNING: IMPORTANT SAFETY PRECAUTIONS!! PLEASE READ COMPLETELY  
BEFORE USING PRODUCT!!**

When using electrical appliances, especially when children or animals are present, basic safety precautions should always be followed to reduce the risk of fire, electric shock, and personal injury, including but not limited to the following:

DO NOT TURN ON DRYER WITHOUT FIRST HOLDING THE DRYER HOSE, as the air volume from the dryer can cause the hose to whip or move rapidly and may cause injury.

1. Do not leave dryer OR the animal unattended while product is in use.
2. Unplug unit when not in use.
3. Do not use extension cords with dryer.
4. Do not unplug unit by pulling on cord.
5. Do not expose dryer to rain or water.
6. Do not use or store dryer where it can fall or be pulled into tub or sink or standing water. If dryer falls into water . . . UNPLUG IT . . . Do not reach into the water!
7. Unplug unit before attempting any maintenance or service.
8. Do not put any object into dryer openings.
9. Keep loose clothing, jewelry and hair away from dryer openings.
10. Do not direct dryer air towards eyes or ears of people or pets.
11. Never use dryer if it has a damaged cord or plug, has been dropped, damaged or exposed to rain or water. Return to **Double K Industries** or an Authorized Service Center for service.
12. When using the cage attachment, do not leave the animal unattended.
13. This product is for use on animals only.
14. Recommended operation by adults only. Use caution when working around children.
15. Do not use attachments not recommended by **Double K Industries**.
16. Do not operate without filters in place. Keep filters clean, as dirty filters limit air intake and may damage the motor or cause overheating.
17. Plug only into a properly grounded receptacle. Always make sure the amperage of the electrical outlet is sufficient for the amperage rating of the product. (See Product Specifications for amperage rating of this product).
18. Do not use product for anything other than its intended purpose.
19. Do not attempt to perform any service or maintenance not outlined in instruction manual.
20. Do not attempt any product modifications or alterations. Do not use, if any parts or switches are damaged. Send to an Authorized Service Center or **Double K Industries** for service.
21. When servicing, use only **Double K Industries** parts.

## **Congratulations!**

You've just purchased the **Double K CHALLENGAIR 2000XL** Forced Air Dryer, which produces warm, high velocity air under pressure to make your animal grooming tasks easier. Your new dryer is designed to provide long, reliable service.

Please read this manual carefully and completely before beginning operation of your dryer and keep this manual in a convenient and safe place for future reference.

A warranty card is included with your dryer and should be filled out completely and mailed to Double K Industries within 30 days of the purchase date of your dryer to validate your warranty. Online registration available at [www.DoubleKIndustries.com](http://www.DoubleKIndustries.com)

Your **CHALLENGAIR 2000XL** has a two year warranty covering the unit against defects in materials and workmanship. Regular maintenance items such as brushes and filters are not included (see warranty card for complete warranty information). It is also important to retain your sales receipt as proof of purchase should service ever be needed.

Your **CHALLENGAIR 2000XL** has one brush-type motor. It is important that the brushes be changed when they become worn down to prevent damage to your dryer motor (brushes are maintenance components and are not covered under the warranty). We suggest checking the motor brushes after every 600 hours of dryer use. Please see section on BRUSHES in this manual for instructions.

A NOTE ABOUT HEAT: Your **CHALLENGAIR 2000XL** has no heating element. The **CHALLENGAIR 2000XL** produces heat by a "flow-thru" motor system, meaning the air is pushed through the motor and is warmed by the natural heat of the motor that occurs during operation. This means greater electrical savings and efficiency for you. The dryer will reach its maximum air temperature after about 2-4 minutes of operation. (Note: The higher the room temperature, the warmer the air from the dryer will be.)

### **ASSEMBLY**

To attach hose to dryer: Your dryer hose has a black hose adapter that will screw onto the hose in a counter-clockwise motion. The adapter with hose attached then fits onto the dryer with a half-twist motion that locks the adapter onto the dryer.

First place the adapter over the snout of the dryer with the Double K logo facing up then turn hose counter-clockwise until the adapter locks in place, the Double K logo should then be sitting horizontally.

To remove hose from adapter: Turn the hose clockwise.

**ATTACHMENTS:** Your dryer is equipped with one hose, 4 twist-on nozzles and 1 compression fit nozzle. To attach nozzles to hose, twist the nozzles "counter-clockwise". Twist clockwise to remove.

### **OPERATION - Switches and Controls:**

1. **2-Speed:**
  - a. **Low Speed / Standard Heat** - Press the motor switch to the left. (I Position)
  - b. **High Speed / High Heat** - Press the motor switch to the right. (II Position)
  - c. **Off** - Turn the motor switch to the middle. (0 Position)
2. **Variable Speed (optional)**
  - a. **Maximum Output** - Turn the dial speed control clockwise to its maximum.
  - b. **Variable Output:** - Turn the dial speed control clockwise to desired air output.
  - c. **Off Position** - Turn the dial speed control counter-clockwise until it clicks off.

## **REQUIRED MAINTENANCE**

### **FILTERS:**

(Procedures below must be performed regularly or as needed to protect dryer warranty status.)

**FILTER CLEANING:** Both the external and internal filters of the **CHALLENGAIR 2000XL** should be kept clean. If the filters become heavily coated with hair and/or dirt, it will reduce the air output of your dryer and can cause damage to the motors or cause the motors to overheat.

**\*Never operate the dryer without all filters in place.**









**To clean external filter:** Vacuum or shake off dirt and hair daily. Filter may be rinsed in water if necessary. Let filter dry completely before reinstalling on dryer.

### **To clean the internal motor filter of the CHALLENGAIR 2000XL:**

1. Unplug dryer.
2. Slide off the back cover of the dryer. This is a compression fit and will come off with a little effort.
3. Remove the filter from the internal filter housing.
4. Clean motor filter disk by vacuuming off hair and dirt, or wash filter gently in cool water. Shake off excess water and allow to air dry completely. (Replace filter if necessary)
5. Place the filter back in the filter housing.
6. Replace dryer back cover.

Any maintenance not explained in this manual should be performed by **Double K Industries** or an Authorized Service Center. Call **Double K Industries** for the name of an Authorized Service Center nearest you. All warranty service must be performed by an Authorized Service Center (or Double K Industries) to protect your warranty status.

### **Attachment List**

Attachment	P/N	Description	Qty.
	870-6	1½" Hose Black on Blue (for Blue Model)	1
	844-6	1½" Hose Black on Grey (for Black Model)	1
	859	2½" Standard Cage Attachment	1
	894	Hose End Black 1½" Screw-On	1
	896	1½" Air Sweep Nozzle	1
	2036	Hose to Dryer 1½" Locking Adapter	1
	2068	1½"-¾" Hi-Velocity Nozzle	1
	2070	Nozzle - Super Hi-Velocity	1

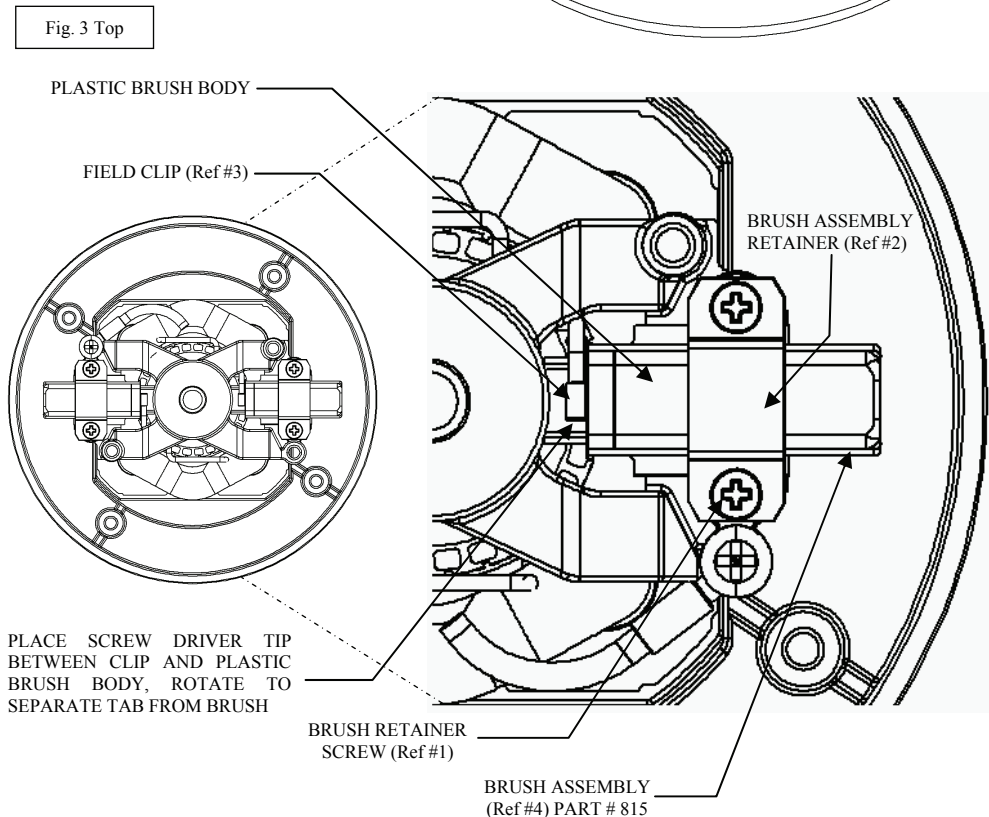
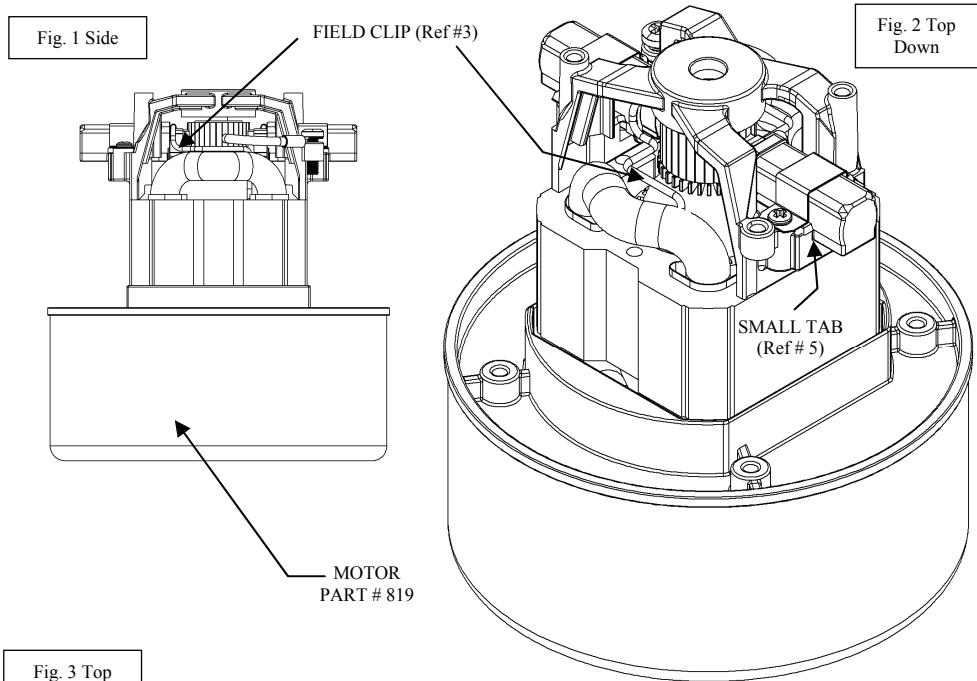

**BRUSHES:** Your **CHALLENGAIR 2000XL** has one brush-type motor. The brushes should be checked for wear after approximately 600 hours of use. If the carbon brushes are worn shorter than 1/4 inch, the brushes should be replaced. Brushes may be ordered from **Double K Industries** or an Authorized Service Center. Please be sure to specify that your dryer is a 2000XL, as the brushes are slightly different from one dryer model to another.

**To check and/or replace brushes:**

1. Unplug electrical cord from wall outlet.

**Disassembly:**

2. Slide off the back cover from the dryer. This is a compression fit and will come off with a little effort.
3. Remove all screws on the outside of the dryer that hold the two halves of dryer housing in place. It may be best to lay the dryer on its side while removing these screws.
4. Each motor will be sitting in place inside the rubber silicone motor mounts. Removing the rubber silicone motor mounts from the motor is not necessary to replace brushes.
5. Disconnect the motor power wires.
6. Motor:
  - a. Loosen the two brush assembly retainer screws (Fig. 3, Ref #1) to loosen the brush assembly retainer (Fig. 3, Ref #2). Remove the field clip (Fig. 3, Ref #3) to remove the brush assembly (Fig. 3, Ref #4) and replacing it with a new one. (Note: IMPORTANT - the brush has a small tab on the bottom that MUST be fitted into the slot on the motor frame for proper positioning) (Fig. 2, Ref #5)
  - b. After the new brush assembly is seated, tighten the brush assembly retainer screws.
  - c. Repeat steps A-B for the brush on other side of motor.

**Reassembly:**

7. Inspect the motor mount for cracks or damage -- replace if necessary. Set the motor back into its original position in the dryer housing. The motor mount has slots that fit over corresponding alignment tabs on the inside of the dryer housing. These slots and tabs must match up for proper fit and function. (Note: In the event that the motor mount is removed from the motor, simply replace it by being mindful to align the contours of the motor mount with corresponding contours on the motor housing.)
8. Reattach the screws around the outside of the dryer making sure the two halves are matching up.
9. After the two halves of the dryer housing have been put together, replace motor filter on back motor and push the burgundy back cover back onto the rear of the dryer. Replace exterior filter on to burgundy back cover. Always make sure all filters are in place before operating dryer.

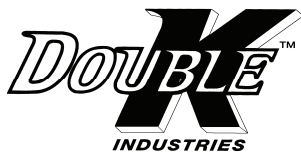

# MODEL 2000XL EXPLODED DIAGRAM

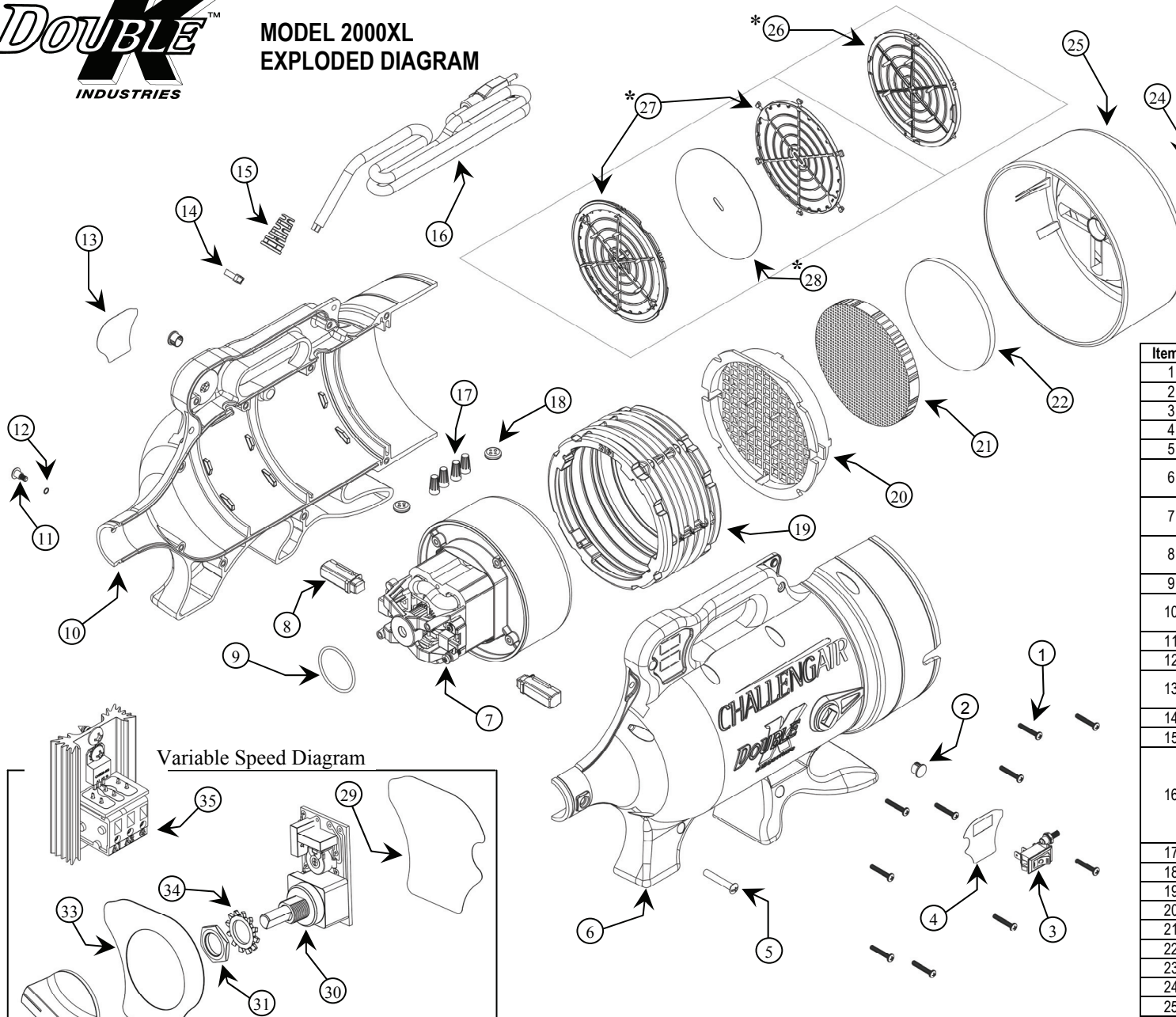

\* Part #s 2177, 2178, and 2100 have been replaced with part #2191. Dryers produced after January 2011 will have #2191 internal filter housing with filter #2196 installed.

\* If your dryer currently has Part #2177, you may still purchase the replacement filters (#2178; 3-pack filters). Part #2177 (snap together filter housing) has been discontinued, if this item needs to be replaced you may do so with part # 2100 or #2191. Part #2191 requires disassembly of the dryer for installation.

## 2000XL PARTS LIST

Item #	Part #	DESCRIPTION	Qty.
1	2163	Screw, 2600 Series Housing	10
2	2123	Housing Plug (models w/o stand)	2
3	2147	Switch Rocker 20A 125VAC 3-Pos Black	1
4	2610	Decal, 2000 2-Speed	1
5	2198	Sex Bolt 1/4 Barrel 24 Thread)	1
6	2158-1	Short Black Housing, Right Side	1
	2156-1	Short Blue Housing, Right Side	1
7	819	Motor 120v 60 Hz LM #115923	1
	805	Motor w/Choke, 230v	1
8	10075	Motor Brushes, 115v	2
	880	Motor Brushes, 230v	2
9	2108	Housing O-Ring for Hose Adapter	1
10	2158-2	Short Black Housing, Left Side	1
	2156-2	Short Blue Housing, Left Side	1
11	2197	Screw, 1/4 Shoulder (#10-24 Thread)	1
12	2131	Shim .24 OD x .190 ID x .015	1
13	2608	Decal, 115v 2000XL 2-Speed	1
	2609	Decal, 230v 2000XL 2-Speed	1
14	426	7" 18 lb. Natural Nylon Quick Tie wrap	1
15	2038	Strain Relief (14/3 cord)	1
16	881	Assy. Cord set 115v	1
	403	230v GB Cord set UK-Ireland	1
	404	230v China Cord	1
	405	230v Eur. Cord set Continental Europe	1
	408	230v Aus Cord set New Zealand	1
17	5537	Nut, Blue Hard Plastic Wire	4
18	2159	Wire Grommet, 4-Hole	2
19	2161	Silicone Rubber Molded Motor Mount	1
20	2191	Internal Filter Housing	1
21	2196	Internal Filter	1
22	2009	Sound Control Foam Disk	1
23	2027	External Filter	1
24	5538	Velcro for External Filter	1
25	2049	End Cap Assy. (Includes 5538 and 2009)	1
*26	2100	Year 2009 Internal Snap-In Filter	*
*27	2177	Year 2010 - Filter Assy.	*
*28	2178	Year 2010 Filter Pack 3 per Order	*
29	2218	Decal 2000 VS 115 , Product Data side	1
30	2168	Speed Control Board (115v)	1
31	2145N	Nut, Rheostat Speed Control - VS	1
32	5509	Knob Switch Black	1
33	2217	Decal VS Pot Side: Variable Speed Units	1
34	2153	3/8 External-Tooth Lock Washer	1
35	2167	Triac PC Board (115v), Assy. w/ Heat Sink	1

### Variable Speed Diagram

